



**CLAY BRICK & PAVER**  
MANUFACTURER'S ASSOCIATION

## 2 Storey Clay Brick Veneer Construction — Made Easy





**CLAY BRICK & PAVER**  
MANUFACTURER'S ASSOCIATION

[www.bricksnz.co.nz](http://www.bricksnz.co.nz)

# Contents

	Introduction	5
1.0	Design Limitations	6
	Concrete Masonry Buildings	
2.0	Building Regulations	6
3.0	Veneer Weight Limitations	6
4.0	Design Height Limitations	7
5.0	Framing	8
	Studs	
	Gable Ends	
	Mid-floor framing	
	Structural Beams	
6.0	Bracing	8
	Table 1.0 Bracing Units	
	Table 2.0 Bracing demand reduction R(BU)	
	Table 3.0 KValues	
7.0	Fire Resistance	10
8.0	System Components and Accessories	10
	Building Paper	
	Flexible Flashing Tapes	
	Air Seals	
9.0	Brick Cavity and Wall Ties	10
	Cavity	
	Brick ties	
	Table 4.0 Length of tie	
	Tie Spacings	
10.0	Shelf Angles – Brick Veneer Above Roof lines	11
	Metal Shelf Angles	
	– Durability	
	– Size of Angles	
	– Installation and Fixings	
	– Temporary Support Block	
	Temporary Support Block	
	Timber Shelf Angles	
	– Installation and Fixings	
	Shelf Angles Under Windows	
11.0	Brick Veneer Panels – Limited Support	14
12.0	Shelf Angles & Secret Gutters – Flashings	14
	Bottom of Sloping Shelf Angles	
13.0	Plastering	15

14.0	Mortar	16
15.0	Bricklaying	16
	Joint Reinforcement	
	Control Joints	
16.0	Design Aspects	17
	Decks, Veranda's and attachments	
	Lintels – Window and Door Openings	
	<b>Method 1 – Traditional Steel Angle</b>	
	Table 5.0 Lintel Bar Sizes	
	<b>Method 2 – Fixing Lintel Angles to the supporting frame</b>	
	Table 6.0 – Size of Lintel Angles – Screw-fixed	
	<b>Method 3 – Steel-less Lintels</b>	
	Table 7.0 – Timber Lintels - sizing	
	Table 8.0 – Timber Lintels - sizing	
	Table 9.0 – Timber Lintels - sizing	
	<b>Method 4 – Precast Reinforced Clay Lintels</b>	
17.0	Technical Support	19
	Technical Details	20
	Figures 1 – 18	
	Figures	23
	A – E, Lintel Options	
	F – Head Flashing	
	G – Temporary Support Brackets	
	APPENDIX – Specification	25

# Introduction

In 2010 the NZ Clay Brick and Paver Manufacturers Association developed a combined certified system for two storey brick veneer. The system enables the construction of 2 storey residential and light commercial buildings which overcomes the maximum veneer height limit of 4m. This system adopts aspects from both the previous systems (BRANZ Appraisal Certificate No. 429 and Appraisal Certificate No. 521) and also incorporates aspects of the testing carried out by BRANZ. It is designed to simplify the process, extend and improve its installation and application, and in doing so, provide a solution for constructing two storey clay brick veneer dwellings in New Zealand, that is cost effective, and all can have confidence in.

In September/October 2008, BRANZ's structural engineers, carried out extensive shake table tests on 2 storey clay brick veneers, which provided valuable information on how this form of cladding was likely to perform during seismic events. Following the Canterbury Earthquake sequence BRANZ have reviewed and found no changes were required to the Two Storey System (other than updating the bracing requirements) and that brick veneer performed well.

The Think Brick two storey system was BRANZ-appraised in 2010 (Appraisal No.690) and is for use in the design and construction two storey residential & light commercial buildings.

**PLEASE NOTE:** This document, Design Note TB 1 - 2012, supersedes all other (previous) two storey clay brick veneer systems.

## IMPORTANT

1. In order to obtain a clear understanding of what is involved, the designer/builder/bricklayer must read, and be familiar with the information contained in this entire brochure prior to designing the house and commencing any work.
2. The information contained in this document is specifically designed and engineered for use only with clay brick product manufactured and/or marketed by companies who are members of the New Zealand Clay Brick & Paver Manufacturer's Association. (NZCB&PMA) or have approval from this organisation to use their system. The brick product must be manufactured to comply with AS/NZS4455. At the time of publication the following companies are members of that Association:  
NZ Brick Distributors Lt (TA – Austral Bricks )  
Canterbury Clay Bricks Ltd  
Clay Bricks Ltd  
Brick & Stone Importers Ltd (TA – Midland Brick NZ )  
NZ Brick Distributor (TA – Monier Bricks)
3. The system ( Design Note TB1) is not only designed to build 2 storey residential dwellings, but is also applicable for use in 2 storey commercial structures, within the scope of NZS3604.
4. More than one manufacturer's clay brick product can be used in the same application.
5. The 'Approved Plans' must be clearly marked, The 2 storey brick cladding system used on this building must be completed to 'Design Note TB1'– no substitute brick product is permitted.
6. It is essential, that each 2 storey design is carefully detailed on the plans using the information in this brochure as a design guide. It is not possible to cover every potential design aspect and this brochure is not intended as a substitute for good design, planning, and detail. Solutions that satisfy the New Zealand Building Code and fundamental design principles are always an option.

# The 2012 2-Storey Clay Brick Guide

## 1.0 DESIGN LIMITATIONS

The following 'Design Limitations' apply to this system. When the structure does not meet these requirements then 'specific engineering design', (S.E.D) is required.

- Concrete ground floor construction.
- Up to 2.0 kPa and 3.0 kPa floor loadings.
- Timber frame construction in accordance with NZS3604 and/or concrete masonry construction in accordance with NZS 4229.
- Maximum thickness of the brick veneer is 90 mm.
- The maximum brick height to length ratio is 0.7. On all veneers that exceed a ratio of 0.5, the bricks are to be half-bonded. Selected architectural detailing such as 'soldier courses', 'quoins', rows of 'header bricks' and the like, are excluded from this requirement.
- General veneer height of 7.5m max. Excluding gables and piers. ( refer Diagram 1- Design Height Limitations)
- The scope limitations of NZBC Acceptable Solution E2/AS1 Paragraph 1.1 in terms of floor area, and with a maximum of 2 stories.
- Situated in NZS 3604 Building Wind Zones up to and including 'Very High'. Wind bracing demand must be calculated in accordance with NZS3604 as it may be the critical lateral loading case.
- A risk score of 0 – 20, calculated in accordance with NZBC Acceptable Solution E2/AS1 Table 2
- Unless otherwise stated in this document, *Design Note TB1 – 2 Storey Clay Brick Veneer Construction*, all aspects in regards to the installation of the brick veneer will conform to the requirements of NZS 3604, NZS 4229 and NZS 4210.

## Concrete Masonry Buildings

The general specification and requirements covered by this document, Design Note TB1, may be applied to structures that are designed to NZS 4229, where the supporting structure is concrete block or concrete walled structures.

The fixing of brick ties must satisfy the requirements of AS/NZS 2699.1:2000 for medium duty (EM) ties.

## 2.0 BUILDING REGULATIONS

*Design Note TB1 – 2 Storey Brick Veneer Construction*, if designed, used and installed in accordance with the statements and conditions of this literature, and supporting BRANZ Appraisal, will meet the following provisions of the New Zealand Building Code:

- Clause B1 Structure
- Clause B2 Durability
- Clause C3 Spread of Fire
- Clause E2 External Moisture
- Clause F2 Hazardous Building Materials

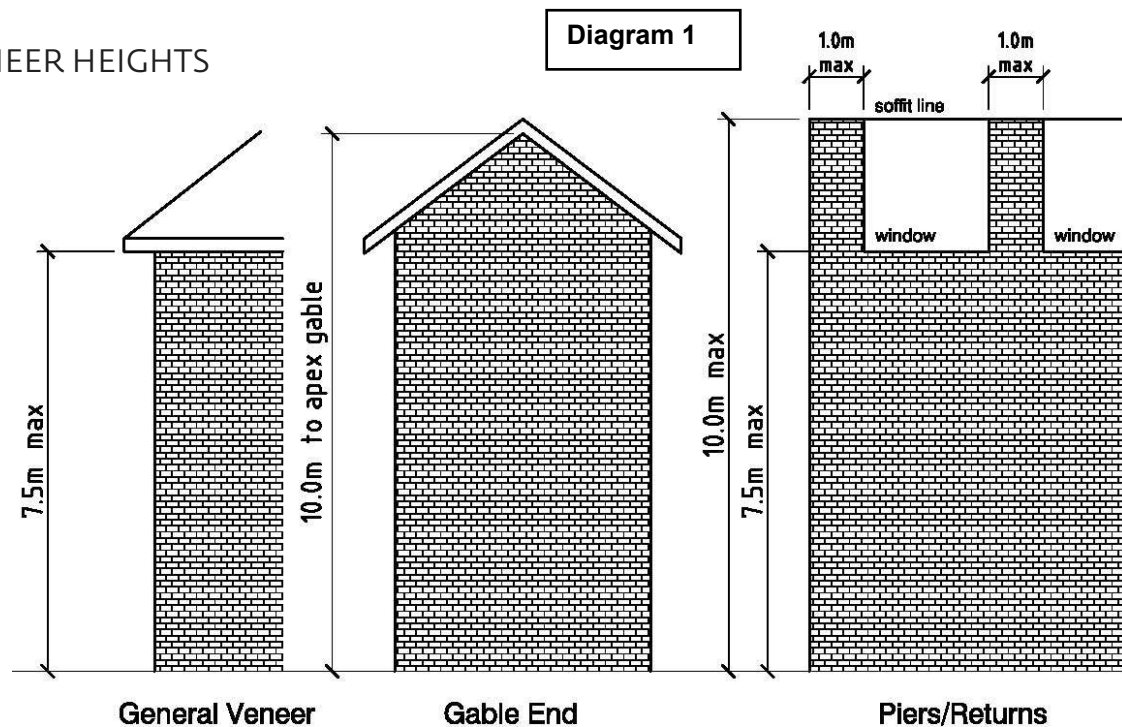
## 3.0 VENEER WEIGHT LIMITATIONS

The installed weight of the clay brick veneer using this system, must comply with the following parameters.

- Veneer weight not to exceed 180 kg/m<sup>2</sup> (will accommodate 90 mm thick veneers)
- In situations where the veneer is to be plastered, up to 20 mm in thickness may be applied to a total weight of 180 kg/m<sup>2</sup> maximum.

**NOTE:** The veneer weights based on a 10 mm mortar joint, can be obtained from the manufacturers covered by this document should that be necessary. A 70 mm brick

## VENEER HEIGHTS



veneer weighs between 115 – 135 kg/m<sup>2</sup> and 90 mm brick veneer weighs between 150 – 170 kg/m<sup>2</sup>. One of the major factors, that affects the weight is the amount of mortar that enters the holes in the bricks.

### 4.0 DESIGN HEIGHT LIMITATIONS

When designing a 2 storey clay brick veneer, it is important to have a clear understanding of the 'Design Height Limitations' and how to apply them in residential designs, or where NZS3604 is applicable in relation to 3 kPa floor loadings.

#### Veneer

The maximum height of a veneer anywhere other than a gable or pier/return, is 7.5m above the supporting foundation of the dwelling.

#### Gable

The maximum height of a gable end is 10.0m at the apex of the veneer.

#### Piers/Return

A pier (not unlike the top of a gable end) is defined as a small projection of brick veneer that exceeds the 7.5m height limitation. The maximum width of the pier is not to exceed 1.0m and the maximum height of the pier is not to exceed 10.0m. Refer Diagram 1.

#### Above Roof Lines

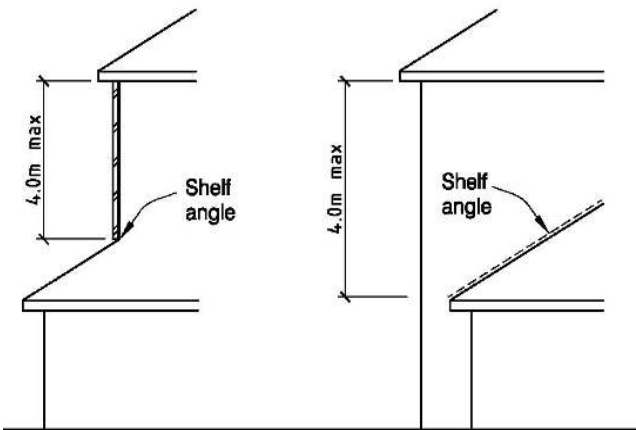
The maximum height of a brick veneer that may be supported on a Shelf Angle above a roof line is 4.0m. Refer Diagram 2.

#### Chimneys

The brick veneer on chimneys above a roof-line can be supported on shelf angles using this system, to a height of 4.0m. The supporting frame would invariably be subject to specific engineering design (S.E.D), and clad in 12 mm H3 plywood to provide a rigid structure. Height restrictions will be governed by Territorial Authority requirements and these need to be considered at the design stage.

Diagram 2

### HORIZONTAL SHELF ANGLES



## 5.0 FRAMING

### Studs

It is important that all framing timber, which includes studs, floor joists and lintels, is kiln dried to 18% moisture content to reduce timber shrinkage and general movement of the frame. The grade shall be a minimum of MSG8 or VSG8.

The external wall frames where the brick veneer is attached, must be constructed in accordance with NZS 3604, minimum 90 x 45 mm studs at 400 mm centres. The timber is to be treated to a minimum of H1.2 which may be used for the entire exterior frame regardless of the attachment of Shelf Angles.

### Gable Ends

Gable end trusses are not to be used in this system. All gable ends are to be framed walls with studs at 400 mm crs. Note: E2 requires a rigid air barrier over gable ends opening into roof cavities, and the 40 mm minimum cavity needs to be considered in this regard. It may be

necessary to line the inside of the framing

### Mid-floor framing

Although kiln dried timber floor joists are permitted, the use of composite joists such as Posi-STRUTS, hyJOIST, and the like are recommended as they virtually eliminate any shrinkage issues, and are lighter in weight.

### Structural Beams

Specific engineering design (S.E.D) is required for most floor beams throughout the structure as per normal design procedures and requirements. It is strongly recommended that only steel beams be used, particularly in mid-floors, which helps eliminate the potential creep that can occur with timber beams. For spans outside *Design Note TB1*, design to a maximum deflection of  $L/300$ .

**NOTE:** Always endeavour to get as much seating for beams as is practically possible and beams should be loaded, eg. Heavy-weight roof on, prior to any bricks being laid.

## 6.0 BRACING

In general, the bracing requirements for two storey dwellings, clad using a 'Heavy Weight' cladding (up to  $220 \text{ kgs/m}^2$ ), especially when a heavy weight roof is involved, have been considerable.

The BRANZ research carried out in 2008, clearly demonstrated the significant contribution modern clay veneer makes to the overall bracing resistance of any structure. This ground-breaking research has resulted in a substantial reduction in the BU's/  $\text{m}^2$  required for earthquake resistance. The total earthquake bracing demand on the building is calculated using Table 1. The bracing demand requirements have changed following the update of NZS3604 in 2012 to incorporate earthquake zones 1-4.

**NOTE,** that wind load bracing requirements shall be determined in accordance with NZS3604.



**TABLE 1.0 – 2 AND 3 kPa FLOOR LOADS  
BRACING DEMAND FOR EARTHQUAKES – 2 STOREY  
CLAY BRICK VENEERS – SOIL CLASSES D & E**

Bracing demand in BU's/m <sup>2</sup> of floor area				
LIGHT ROOF		Earthquake zones		
Location	4	3	2	1
Lower storey walls – No veneer above	37.4	28.7	17.2	12.0
Lower storey walls – Veneer above	43.8	33.7	20.2	14.3
Top storey walls	22.0	16.9	10.2	7.1
HEAVY ROOF				
Lower storey walls – No veneer above	43.0	33.0	19.8	13.9
Lower storey walls – Veneer above	54.4	41.8	25.1	17.6
Top storey walls	34.6	26.6	16.0	11.2

**NOTE:** For Soil Class C multiply the values in the above Table 1.0 by a factor of 0.8.

For Soil Classes A & B multiply the values in the above Table by a factor of 0.66.

### Potential to reduce Bracing Units

**IMPORTANT NOTE:** After distribution of the demand from Table 1.0 above, through the building, the bracing demand for a particular exterior wall bracing line, can be reduced by a conservative estimate of the brick veneer bracing resistance provided the following dimensional requirements are adhered to.

- each exterior lower floor wall must have veneer over at least 40% of its length and the minimum veneer panel length between openings or at corners must be

400 mm, if there is veneer in the storey above.

- if the 40% criteria and the 400 mm length criteria are not reached then that wall cannot have in reduction applied to the bracing demand.

### Calculation of bracing demand reduction for exterior walls

**TABLE 2.0 - BRACING DEMAND REDUCTION R(BU)**

Masonry veneer lower storey only	R = 0 for upper storey walls
	R = KLH <sub>L</sub> for lower storey walls
Masonry veneer both storeys	R = KLH <sub>U</sub> for upper storey walls
	R = KLH <sub>T</sub> for lower storey walls

#### Where:

- L is the gross veneer length (m) [window and doors included]
- H<sub>L</sub>, H<sub>U</sub>, and H<sub>T</sub> are the lower and upper storey heights and the total height respectively.
- K is given in the Table 3 below.

**TABLE 3.0 - K VALUES**

Seismic Zone	4	3	2	1
Soil Classes D & E	8.00	6.16	3.69	2.61
Soil Class C	6.31	4.77	3.07	2.15
Soil Classes A & B	5.08	3.85	2.46	1.69

**NOTE:** There is **no reduction** in demand for the interior walls.

## 7.0 FIRE RESISTANCE

The Two Storey Clay Brick Veneer System has been tested and shown to have a fire resistance rating of greater than 30/30/30 when the internal face of the wall is lined with 13 mm Standard Gib Plasterboard.

The Two Storey Clay Brick Veneer System is suitable for use as an external wall cladding on all buildings in accordance with NZBC Acceptable Solution C/AS1 Part 7, Paragraph 7.11.2(a)

In addition to the above comments, PBS Ltd can provide Fire Rating solutions, worth exploring, using Eterpan.

## 8.0 SYSTEM COMPONENTS AND ACCESSORIES

### Building Paper

The 2 Storey Brick Veneer Systems must be installed over building paper or wrap complying with NZBC Acceptable Solution E2/AS1, Table 23, or other BRANZ Appraised breather-type membranes. It is strongly recommended that 'fire retardant' building paper is specified, and is certainly essential if a flashing material such as 'Nuraply' is used, which requires a naked flame for installation.

**NOTE:** The building wrap is to be stretched tight over the frame and secured to the framing using tape that helps prevent staple pullout when the insulation is installed, which has the potential to not only reduce the cavity width, but cause bridging between the veneer and the frame. The wrap is to be installed horizontally, continuously around corners, lapped a minimum of 75 mm at horizontal joints and 150 mm minimum over studs at vertical joints.

Non-rigid air barriers must have an air resistance of equal to or  $>0.1 \text{ MN s/m}^3$ . Where rigid sheathings are  $>5.0$  mm are used, the brick tie fixing length must be increased by a minimum of the thickness of the sheathing.

### Flexible Flashing Tapes

Flexible sill and jamb flashing tapes shall be installed around all penetration openings in the structural frame. Flexible flashing tapes shall comply with NZBC Acceptable Solutions E2/AS1 Paragraph 4.3.11, or be covered by a valid BRANZ Appraisal for use around window and door joinery openings.

### Air Seals

Air seals shall be installed in the gap between the joinery reveal and the opening framing. The air seal shall comply with NZBC Acceptable Solution E2/AS1 Paragraph 9.1.6, or be a self-expanding, moisture cure polyurethane foam air seal covered by a valid BRANZ Appraisal for use around window, door and other wall penetration openings.

## 9.0 BRICK CAVITY & WALL TIES

### Cavity

The brick veneer cavity is to be a minimum of 40 mm and a maximum of 60 mm in width. It should be noted that the cavity width is measured from the tie fixing to the inside face of the brick veneer.

Washouts are to be installed at the base of these veneers every 10th brick, and at each corner to facilitate the cleaning of the cavity during construction.

### Brick Ties

The brick ties to be used in this system are to be screw-fixed brick ties, which comply with NZS2699.1. The minimum strength tie required is an EM (Earthquake Medium) tie. The durability is to comply with the requirements of NZS3604.

Use stainless steel ties in 'Sea Spray' zones.

**TABLE 4.0 - LENGTH OF TIE**

Cavity	70 mm Brick	80 mm Brick	90 mm Brick
40	85 mm	85 mm	85 mm
45	85 mm	85 mm	105/115 mm
50	85 mm	105 mm	105/115 mm
55	105 mm	105/115 mm	105/115 mm
60	105/115 mm	105/115 mm	105/115 mm

### Tie Spacings

Veneers up to 140 kg/m<sup>2</sup> [70 mm thick veneers]

- Horizontally 400 mm crs into studs
- Vertically 400 mm crs max.
- Openings Within 200 mm of the edge of all openings
- ShelfAngles 1st Row within 200 mm of the Shelf Angle
- Foundation 1st Row within 400 mm of the rebate

Veneers between 141 and 180 kgs/m<sup>2</sup>  
[over 70 mm thick veneers]

- If using EH (Heavy Duty) ties, then as above.
- If EM ties then as follows:
  - Horizontally 400 mm crs into studs.
  - Vertically 400 mm crs into studs up to 3.0 m from foundation, then 300 mm crs max.

**NOTE:** If the positioning of a tie is not specified in this document, or stipulated in an approved system such as the 'Steel-less Lintel' system, then NZS3604 and NZS4210 will apply.

## 10.0 SHELF ANGLES - BRICK VENEER ABOVE ROOF LINES

Simply put, a 'ShelfAngle' is typically a galvanised metal angle, fixed to the timber framing to carry brick veneer by transferring the load to the foundation or structural beam by way of the studs (framing).

A 'ShelfAngle' can be installed anywhere provided the angle can be fixed at approx. 400 mm crs (measured in the horizontal plane). However, 'ShelfAngles' are typically used to carry brick veneer horizontally above a skirt roof or alternatively, on a slope where a lower roof forms a junction with an upper level wall.

A 'ShelfAngle' (steel or timber) can carry 4.0 m of brick veneer. In situations, where the height of the veneer to be carried, is greater than 4.0 m, install an additional galvanised steel shelf angle at a level no greater than 4.0 m from the first 'ShelfAngle'. (Would rarely occur)

All bricks laid on 'ShelfAngles' should have a 10 mm mortar bed under the first brick; this is especially important when a membrane flashing has been used over the top of the 'ShelfAngle' and the brick has been cut. There is a potential here for a sharp edge to penetrate the flashing.

### Metal Shelf Angles

#### Durability

Metal ShelfAngles need to be hot dipped galvanised to meet the durability requirements of Section 4 of NZS3604. Where holes are drilled or the angle cut after the angle has been galvanised, these areas are to be sprayed using 'cold galvanising' spray coating.

In 'Sea Spray' zones, (500 m from the high water mark), the hot dipped galvanised steel angles are to be coated with epoxy powder coating to NZS3604 or stainless steel. The durability requirement could be considered satisfied, where the HD galvanised shelf angle is completely protected from the exterior atmosphere by a durable flashing material.

### Size of Angles

The angle needs to be of sufficient size, that it can accommodate the cavity width plus support the brick, but keeping the outside edge of the angle inside the face of the brick veneer for aesthetics.

The standard size of angles are; 100 x 75 x 6 mm, 100 x 100 x 6 mm, for 70/80 mm brick veneer and 75 x 125 x 6 mm for 90 mm brick veneer. Note: The width of the cavity largely determines the size of the angle to be used.

### Installation and Fixings

It is not critical that 'ShelfAngles' are joined or continuous, brick is more than capable of spanning gaps of say 200 mm should the need arise, as it does from time to time.

The 'ShelfAngles' should not be fixed to the framing until the veneer below has reached its full height so that the 'ShelfAngle' can be correctly aligned with the veneer ie. height of the angle.

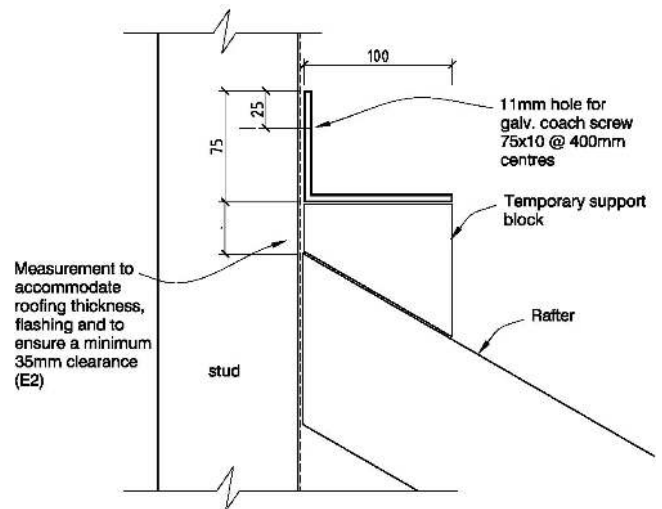
**IMPORTANT:** Where a flashing material is installed below the 'ShelfAngle' and taken up behind it, E2 requires a minimum gap of 35 mm (rec. design for 50 mm) between the underside of the angle and the top surface of the flashing material. This is to prevent leaves and other debris from restricting the flow of water and to facilitate cleaning. If the flashing material is installed over the top of the 'ShelfAngle', the angle can be closer to the roof, and the 35 mm would not apply.

To simplify the installation of the 'ShelfAngles' above a horizontal roof-line, the use of a temporary block to support the angle, is invaluable. (Diagram 3)

The 'ShelfAngle' is to be fixed into load-bearing timber at max 400 mm crs (measured horizontally) using 75 x 10 mm galvanised coach-screws or equivalent bolts. An 11 mm hole is to be drilled in the vertical leg of the angle, 25 mm from the top edge of the angle. Where the coach-screw is to go through plywood bracing or similar, increase the length of the coach-screw to 90 mm. Use a 6 mm pilot hole in the timber to accommodate the 10mm coach-screw.

Diagram 3

### TEMPORARY BLOCK & SHELF ANGLE FIXING



**IMPORTANT:** Ensure that where 'ShelfAngles' are to be fixed, there is no possibility of the coach-screw penetrating electrical cables, or water pipes.

Depending on the number of 11 mm holes to be drilled, it is advisable to clearly mark the positioning of the holes on the 'ShelfAngles' and take them to an engineering shop to have the holes either drilled or punched. It is strongly recommended that the drilling of holes with the angle in position is avoided as this can be dangerous and difficult.

Although in most situations the holes are fully flashed, it is recommended they should be coated with a metal primer or cold galvanising paint.

**NOTE:** The first row of brick ties to be within 200 mm of the ShelfAngle.

Where it is practical to do so, it is strongly recommended that 'ShelfAngles' are installed by experienced tradesmen or the builder. Check angle for 90°.

## Timber Shelf Angles

Experimentation has demonstrated that screw-fixed brick ties are very good at carrying dead-load, and that in reality, once the mortar has cured, there is very little direct load on the ShelfAngle; virtually all the load is transferred via the ties into the supporting structure. This development has led to the introduction of timber shelf angles, which may not be suitable for all situations, depending on the design.

It is also important to remember that the design of the timber 'ShelfAngle' does not need to be exactly as detailed below, however, the fundamentals of the design need to be incorporated in the proposed solution, eg. the method of fixing must include 100 x 10 galvanised coach-screws plus 100 x 4 mm FH galv. nails. Fig. 1,3,7

### NOTE:

1. That in all cases involving timber 'ShelfAngles', the flashing material is installed over the top of the 'Shelf Angle' providing total protection of the timber.
2. That the width of the 'ShelfAngle' may limit the width of the brick to be used.
3. If the veneer is to be plastered, consideration should be given to how the bottom edge of the veneer and its relation to the 'ShelfAngle' is finished to provide a crisp edge.
4. The timber to be used in this application must be kiln dried H3.2
5. Under no circumstances are fixings to penetrate the flashing membrane on shelf angles through the horizontal plane.

## Installation and Fixings

The following is one method of installing a timber 'ShelfAngle' that provides a seating of 90 mm in width, meaning a 70 mm brick would overhang 20 mm.

Secure a 90 x 45 mm, H3.2 wall plate along the wall, every

400 mm to the studs or load-bearing framing, using 2/100 mm x 4 mm galvanised FH nails. Then install a 100 mm x 10 mm galvanised coach-screw through the wall plate into each stud, 400 mm centres. The head of the coach-screw must be countersunk into the plate.

Then fix an additional 90 x 45 mm H3.2 wall plate to the already installed plate using a minimum of 2/100 x 4 mm galvanised FH nails at 400 mm centres. An additional 19 mm batten may be added to the 90 mm timber to provide a seating of 109 mm if required. The batten is to be H3.2 fixed using 60x2.8 Galv. FH nails at 400 mm crs.

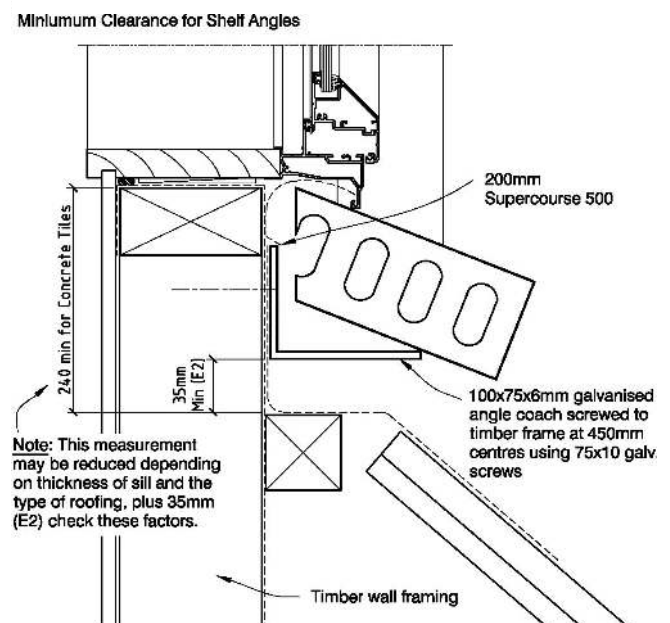
**NOTE:** The first row of brick ties to be within 200 mm of the ShelfAngle.

## Shelf Angles Under Windows

It is important when designing the position and size of windows, that their location in relation to the roof is considered. Refer Diagram 4.

Diagram 4

### UPPER LEVEL WINDOW LOCATION



A minimum clear distance of 240 mm should be allowed for between the roof and the base of the window. This is to allow for adequate fixing of the masonry and to accommodate the window sill.

### 11.0 BRICK VENEER PANELS – LIMITED SUPPORT

In some situations, areas of wall are supported entirely by the roof framing, and have no support from the floor below. Examples are dormer windows and small gable ends. The brick veneer panels can be supported on either the timber or steel 'Shelf Angle' supports detailed above.

In these cases, special attention has to be given to the trimmer rafters because of the additional weight of the veneer supported. The rule is, that in these situations 3 trimmer rafters be installed each side of the dormer (or similar structure) to carry the additional load.

The limit on the area of veneer supported this way is 1.5m<sup>2</sup> with a maximum height of 1.2m. If the design is outside these limitations consult a structural engineer.

#### ! LIMITED SUPPORT

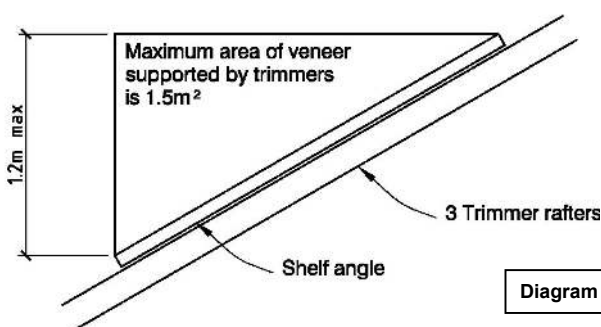


Diagram 5

### 12.0 SHELF ANGLES & SECRET GUTTERS – FLASHINGS

Brick veneer as a cladding carries a durability requirement of 15 years, however, the fixings, which include the shelf angles and brick ties, carry a 50 year durability requirement. It should be stated, that contrary to popular belief, with the use of modern diamond saws, removing brick veneer and repairing flashings is not as difficult as one would imagine. It is in fact, simpler than many other cladding options.

It is important that the correct material is selected to be used as a flashing in situations involving 'Shelf Angles' or 'Secret Gutters'. The aspects that need to be considered are; durability, accessibility for repairing and compatibility with surrounding materials. The products mentioned in this document are provided as a **guide only** and other products may be equally suitable. Advice and guidance should be obtained from individuals, who have specialist knowledge in regards to flashings and their suitable application.

#### Examples of materials that may be used are as follows:

Acrylead, Nuraply 3P, Bitu-Al, Butynol. If Zinalume<sup>®</sup> metal flashings are to be used, they are not to be exposed to the mortar, and therefore it is essential that this material is not installed between the brick and the shelf angle. Do not use ordinary lead, and Acrylead must be painted both sides over the primer coating.

When flashing the area between the wall and the roof, which would incorporate either a timber or metal 'Shelf Angle', the following guide-lines should be adhered to:

- Extend the flashing a minimum of 200 mm onto the roof.
- On metal roofs, ensure the ends of the roofing are turned up for added protection.
- If the flashing is secured behind the 'Shelf Angle' ensure there is a suitable flashing between the top edge of the 'Shelf Angle' and the building wrap. This

could be an approved flexible flashing tape or a 200 mm wide polyethylene flashing with another layer of building wrap covering the whole flashing detail.

- A Zincalume® metal flashing may be used under a 'Shelf Angle' provided the junction between the up-stand of the angle and the building wrap is correctly flashed as described above.
- Where a flashing material that requires support, spans a distance in excess of 40 mm, provide a packer to afford support for the flashing material, unless metal.
- Materials used for flashing must comply with section 4.3 E2/AS1 list of approved flashing materials.

### Bottom of Sloping Shelf Angles – Kickout Flashings/Stop-ends

In regards to weathertightness and the flashing of any part of a brick veneer, the simple question must be asked; 'Where does the water go?' Water passes through the bricks, runs down the inside face – what happens to it then?

This is especially relevant in situations involving sloping 'Shelf Angles'. The water runs down the angle discharging at the bottom. If the angle is less than 1.2m in length and the area of veneer reasonably well protected, the minor discharge could be easily handled by the cavity below, provided it is not close or discharging onto a window or door head.

However, in most cases, the capture of this water is important and the best method is to install a plastic or metal stop-end or kick-out flashing to either discharge the water into the gutter system or on to the roof. There are several ways this can be achieved, and an example of a large and small 'Stop-end', which both come in a left and right hand configuration, are the Gerard Stop-End and the Ardex BT700/BT701 Kick-out Flashing. (Refer to Fig's 5 & 6)

**NOTE:** Where an opening in the veneer is such that it would allow birds access to the cavity, it is important to bird-proof this area.

## 13.0 PLASTERING

The two storey system outlined in *Design Note TB1*, may be plastered. When plaster and paint are applied to a brick veneer cladding, it takes a system that already manages water superbly, and waterproofs it.

The maximum weight of the plastered veneer is restricted to 180 kg/m<sup>2</sup> which does not exceed the maximum weight for a "Heavy Weight" cladding specified in NZS3604, which is 220 kg/m<sup>2</sup>. It should also be remembered that a plastered/painted veneer holds no water compared to a saturated face veneer, which could weigh around 10% more when saturated than dry.

It is recommended, that thin modified plaster coatings be used. Avoid plaster coatings that are greater than 15 mm in thickness where practical to do so. Plaster coatings must not exceed 20mm in thickness.

It is important to research and provide a comprehensive specification when plastering clay brick veneers, to provide an excellent finish and avoid potential cracking. The following are a few important considerations.

- Bricks must be laid to a high standard specification.
- Control joints to be installed in high risk areas.
- Veneers with plaster coatings exceeding 15mm in thickness to have Control Joints through the bricks and the plaster coating at all corners and in the centre of walls of lengths greater than 8.0m that do not contain openings.
- Tie the top row of bricks well.
- Good site management of the veneer is important to avoid damage by other trades people through impact.
- Do not touch the veneer for at least 7 days after installation.
- It is recommended to install 'Bricklock STR' and 'Bricklock CNR' joint reinforcement or similar, every

800 mm up the height of the veneer, but not in the same joints as the brick ties.

**NOTE:** This system also covers two storey brick veneers, that are either 'painted' or 'bagged.'

## 14.0 MORTAR

The earthquake performance of brick veneer is dependant on the quality and strength of the mortar that holds the whole system together. Recent testing of site mixes has raised some concerns regarding the strengths of these mortar mixes. The NZ Standards call for 12.5 MPa in structural brickwork without stating a specific strength in standard veneers. In two storey brick veneers, the strength of the mortar cannot be compromised. It is essential that the mortar can be relied upon to achieve a strong dowelling effect between the bricks.

**IMPORTANT:** The mortar to be used on all brick veneers, that are using this system, Design Note TB1, are to be either mixed to a ratio of 4 sand to 1 cement or must be factory manufactured bagged trade mortars, to ensure that the strength of the mortar can be relied upon. It is recommended that bagged trade mortar's be specified for their controlled quality.

## 15.0 BRICKLAYING

This document is designed to explain the two storey clay brick system, not to provide in depth detail on how to lay bricks, and what is good trade practice. These aspects are covered in other relevant technical literature and NZ Standards. However, a few important requirements are mentioned.

- The quality of the bricklaying is important. There should be no difference regardless of whether it is being plastered or not.
- Mortar joints should be specified as 10 mm thick, and should be within +/- 2 mm and are not to exceed +/- 3 mm.

- The bonding of 'Standard' bricks may be a third bond (metric bond). All non-standard sized bricks must be half-bonded. Refer 1.0 Design Limitations.
- Ensure the bricks are well blended and the bricks kept dry during the laying process; ie. not saturated.
- The top brick of all veneers is to be tied in every second perpend joint. Where practical to do so, install vent holes in the second row from the top of the veneer to avoid weakening the top row. Refer Fig.18

### Joint Reinforcement

It is recommended, that within the top 2.0m of the brick veneer, two mortar courses not containing brick ties, and spaced approximately 800 mm apart, contain 'Bricklock STR' and 'Bricklock CNR' joint reinforcement or similar galvanised wire joint reinforcement. This addition will provide further strength to the veneer, and provide redundancy to help prevent any future cracking, and a degree of insurance during future seismic events.

### Control Joints

When constructing houses clad in clay bricks, movement control joints are unnecessary under normal building conditions. Clay bricks may expand slightly, but the degree of expansion is so small, that to current knowledge, it has never presented a problem. Cracking in clay brick veneer invariably presents no issues to do with weathertightness or structural performance – it is a cosmetic issue.

It should be noted, that 'Control Joints' are not required in clay brick veneers where the floor slab and foundations are constructed on expansive clays; provided the foundations have been correctly designed.

However, when constructing a wall cladding system where a rigid structure is tied to a flexible structure, common-sense must always apply. Should a situation arise where there is a high probability of significant movement occurring between adjacent veneers, e.g. change in foundation design; small panels bonded to



large panels etc, consideration should always be given to separating the veneer panels with a vertical control joint. This joint is generally 10 mm wide, but under some situations it may only require a saw cut in the brick, butt jointed, which is more discreet. In veneers, a Control Joint is in effect a controlled crack.

The veneer must be tied to the timber within 200 mm of each side of the control joint in the same manner in which an opening is treated, therefore must be considered at the design stage to ensure timber is installed in the location required.

## 16.0 DESIGN ASPECTS

Good design and specifications can simplify the building process, reduce costs, shorten construction time-frames, and ultimately provide a rewarding outcome. The following aspects of the design need careful consideration.

### Decks, verandas and attachments

The simple rule with any attachment to a brick veneer dwelling, such as a deck, veranda, portico etc, especially on a two storey dwelling, is to build the structure, design and install support brackets to the framing, lay the bricks to full veneer height around the brackets, and finally attach the proposed external structure to the support brackets.

There are significant benefits in following the above procedure. It simplifies the bricklaying, reducing costs in the process. It avoids complex flashings allowing water to pass through the veneer at any height and exit via the weep holes. The installation of steel support brackets, that span the veneer, provide a fixing point for temporary scaffold, and transfer the load back to the structural frame.

An alternative to the above concept is to keep structures like decks completely independent of the main structure and free-standing.

### Lintels – Window and Door Openings

Careful consideration to the method by which the brick veneer across the head of openings is supported, is required at the design stage.

One of the 4 following fundamental methods may be used.

#### Method 1 – Traditional Steel Angle – Fig. A

The galvanised steel angle spans from one side of the opening to the other and sits on the brick veneer forming a bridge upon which the bricks may be laid. On openings up to and including 2.0 m, a seating of 100 mm each side is required. On openings over 2.0 m, a seating of 200 mm is required. What is important is that the steel angle is kept completely free of the framing. Prop all lintels for a min. of 7 days.

Recent seismic testing by BRANZ has demonstrated that the performance of the brick ties in managing loads means the size, spans of angle and amount of brick carried, can be simplified. The following table may be used for both 70 and 90 mm bricks, and the height of the veneer supported is not important.

**TABLE 5.0 – LINTEL BARS SUPPORTING VENEER OVER OPENINGS**

Max.Span (mm)	Size of Angle
3000 mm	80 x 80 x 6
3500 mm	100 x 100 x 6 or 125 x 75 x 6
4500 mm	125 x 75 x 8
4800 mm	125 x 75 x 10

#### Method 2 – Fixing Lintel Angles to the supporting frame. Fig. B

Galvanised steel lintel angles may be fixed directly to the timber framing lintels, using 75x10 mm coach-screws at 450 mm crs. It is essential that the length of the angle is

kept 5 mm short at each end of the angle on face veneers, and 10 mm short of the opening each end on plastered veneers. This will permit the framing and attached angle, to move without interfering with the brick veneer, should there be slight movement in the frame.

**Note:** This also applies to any metal head flashings.

**TABLE 6.0 - SIZE OF LINTEL ANGLE - SCREW FIXED**

Cavity Width	Angle Size	
	70 mm Brick	Up to 90 mm Brick
40 mm	100x75x6 100x100x6	120x100x6
45 mm	100x75x6	120x100x6
50 mm	100x75x6	120x100x6
55 mm	120x100x6	125x75x6
60 mm	120x100x6	125x75x6

**Method 3 – Steel-less Lintels. Fig. C, D, E**

The ‘Steel-less Lintel’ system was developed in conjunction with BRANZ as an ‘Alternative Solution’ to using galvanised steel lintels to support brickwork over openings, dramatically reducing costs. This solution also overcomes any potential durability issues with steel in ‘Sea Spray’ zones.

Experimentation has shown that a steel lintel across openings only supports the brick until the mortars have cured. The weight of the brick above the opening is carried by the framing above the opening to the timber lintel, and by arch action, to the brick piers on either side of the opening. Alternative span tables to NZS3604 for the timber lintels are provided below when using the steel-less method. Consideration has been given to roof weight and loaded dimension in the formulation of these tables. For temporary support brackets see Fig. G.

**TABLE 7.0 - TIMBER LINTELS SUPPORTING ROOF AND VENEER REGARDLESS OF HEIGHT**

Timber Lintel Size	Maximum Span
140 x 90	1.2m (1.1)
190 x 90	1.6m (1.4)
240 x 90	2.0m (1.8)
290 x 90	2.4m (2.2)

Note that the value in brackets is for roofs with 1.0kPa snow loads

**TABLE 8.0 - TIMBER LINTELS SUPPORTING ROOF, FLOOR UP TO 3 kPa LIVE LOAD, AND VENEERED TOP STOREY WALL. (INCLUDING GABLE END WALL WHERE LOADED ROOF DIMENSION IS TAKEN AS 3M)**

Timber Lintel Size	Maximum Span
140 x 90	1.0m (0.9)
190 x 90	1.3m (1.2)
240 x 90	1.6m (1.6)
290 x 90	2.0m (1.9)

Note that the value in brackets is for roofs with 1.0 kPa snow loads

**TABLE 9.0 - TIMBER LINTELS SUPPORTING ROOF AND VENEER UP TO 400MM (APPLIES TO SINGLE STOREY OR TOP STOREY ONLY)**

Timber Lintel Size	Maximum span for Light Roof	Maximum span for Heavy Roof
140 x 90	1.5 (1.2)	1.3 (1.1)
190 x 90	2.0 (1.6)	1.7 (1.5)
240 x 90	2.5 (2.0)	2.2 (1.9)
290 x 90	3.0 (2.4)	2.7 (2.3)

**Note:**

1. That the value in brackets is for roofs with 1.0kPa snow loads.
2. That Tables 7, 8 & 9 apply to 70 and 90 mm bricks

Although not essential, it is recommended that bricks be laid in a 'Soldier Course' manner across openings. The following specification must be adhered to:

- Temporary support must remain in place for a minimum of 7 days.
- Where openings are over 1200 mm and the brickwork depth above the opening exceeds 300 mm, 'Bricklock STR' joint reinforcement or similar galvanised wire joint reinforcement, is to be installed within 400 mm of the underside of the brickwork and extend 200 mm each side of the opening.
- A gap of 5 mm – 10 mm is to be left between the underside of the brickwork and the top of the metal flashing.

**Brick Ties**

- Standard soldier course bricks are to be tied every 2nd perpend with 2 brick ties spaced 150 mm apart. Double height bricks as soldiers tied every vertical perpend with 2 ties.
- In Standard stretcher bond – 1 tie on edge every 230 mm in the bottom two rows of bricks. The ties to be positioned in the perpend mortar joints.
- Note: Minimum depth for Soldier Course bricks or double height bricks is 160 mm. Minimum depths in stretcher bond for standard height bricks is 240 mm.

**Method 4 – Precast Reinforced Clay Lintels**

Some clay brick companies manufacture and market a 'Precast Reinforced Clay Lintel' for use on clay brick veneers, if they are to be plastered.

They are normally 162 mm x 90 mm and are engineered to span up to 2800 mm openings. If you are interested in exploring this option, contact the brick company concerned to obtain information on availability and any limitations to the use of this method.

**17.0 TECHNICAL SUPPORT**

The information contained in this brochure should satisfy most situations in regards to the installation of two storey brick veneers covered by Design Note TB1.

However, should you require additional help or guidance, contact any of the following companies for assistance. Please note: Where the make of brick has been specified, please contact the company involved for their assistance.

Austral Bricks                      0800 287 8725

Canterbury Clay Bricks 03 318 8203

Clay Bricks Ltd                      07 828 9919

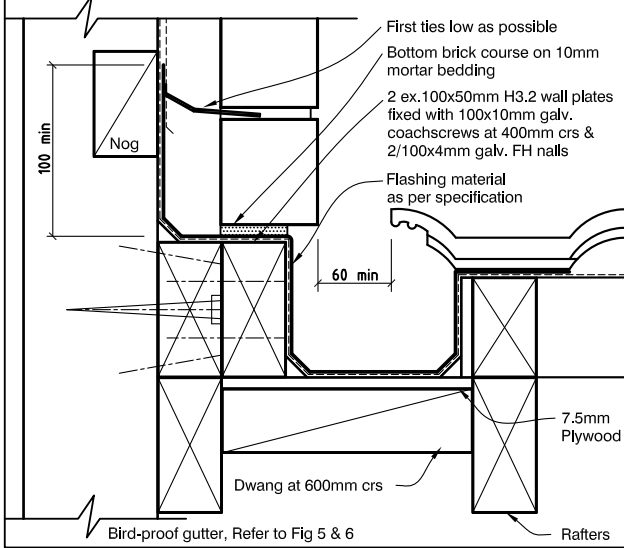
Monier Bricks                      0800 507 600

---

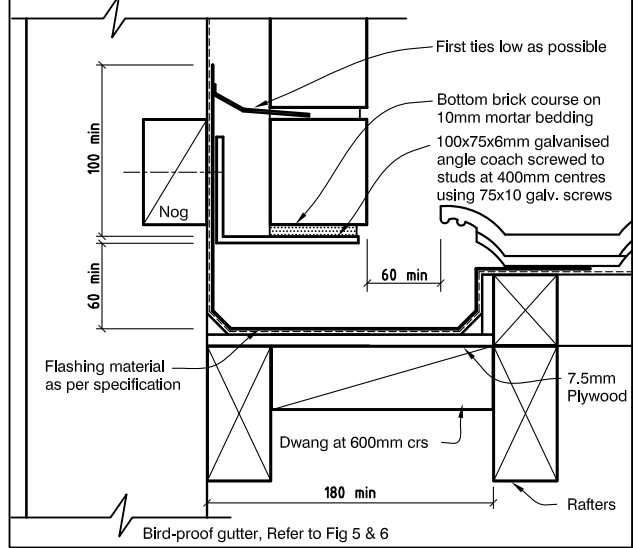
**NOTE: Steel Framed Construction**

Two storey brick veneer dwellings may be constructed using light gauge steel framing; however specific engineering design (S.E.D) is required for the framing in relation to the brick veneer. Specific details are also required to cover fixings, shelf angles etc. [www.nashnz.org.nz](http://www.nashnz.org.nz)

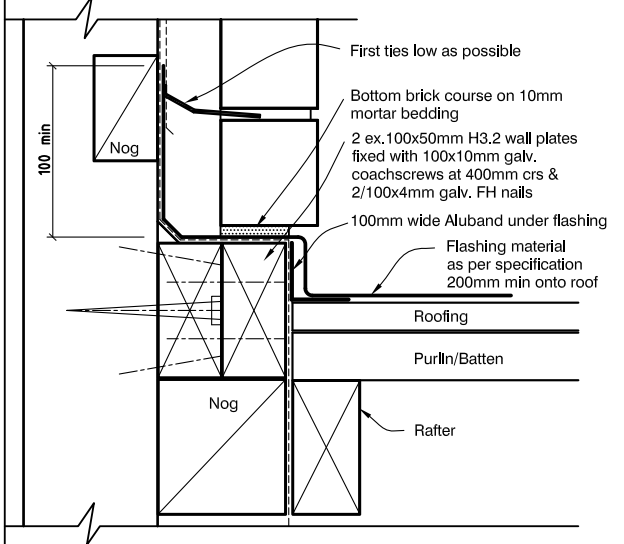
**FIG.1 WALL AT SIDE OF ROOF SLOPE**  
Option: Secret Gutter - Timber Support



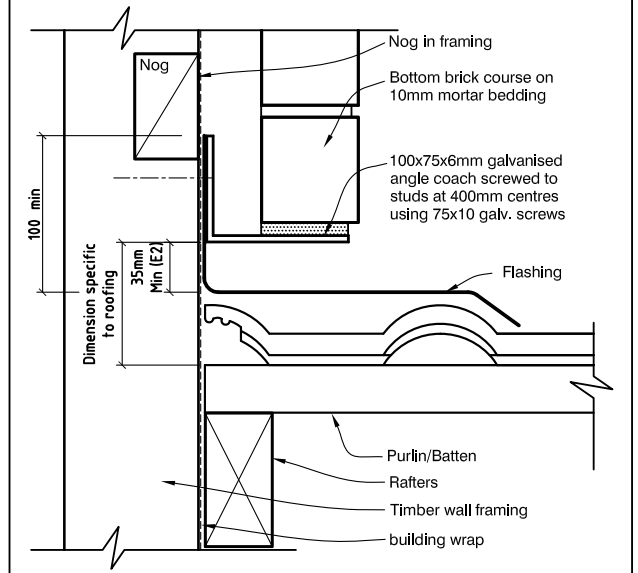
**FIG.2 WALL AT SIDE OF ROOF SLOPE**  
Option: Secret Gutter - Steel Angle



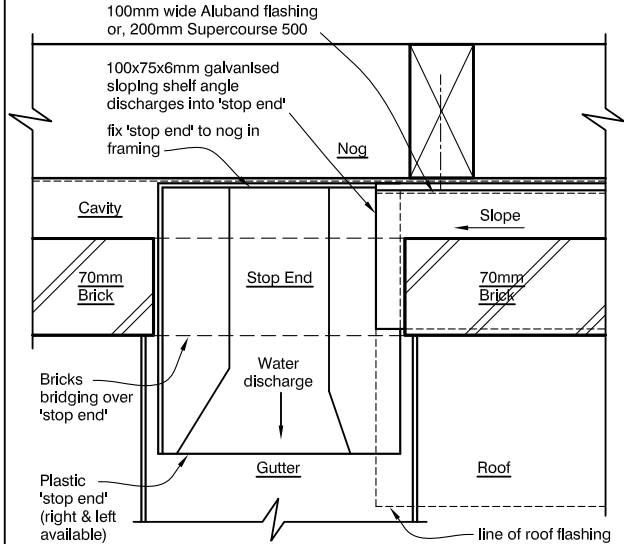
**FIG.3 WALL AT SIDE OF ROOF SLOPE**  
Option: Flashing over Roofing Material



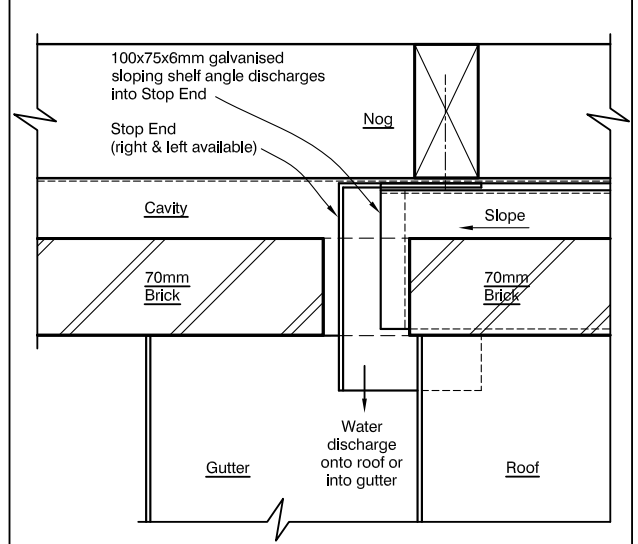
**FIG.4 WALL AT SIDE OF ROOF SLOPE - Alternative**



**FIG.5 BASE OF SLOPING SHELF ANGLE - Plan View**  
Large Stop End (eg Gerrard Stop End)



**FIG.6 BASE OF SLOPING SHELF ANGLE - Plan View**  
Small Stop End (eg Ardex BT700 Kickout Flashing)



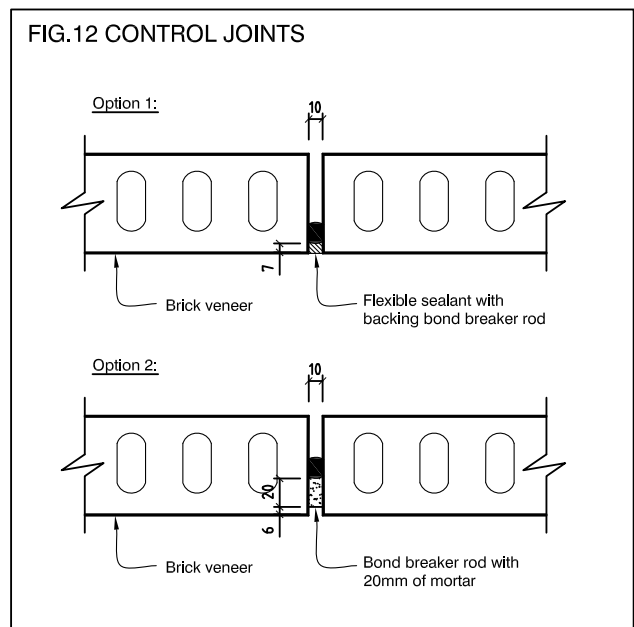
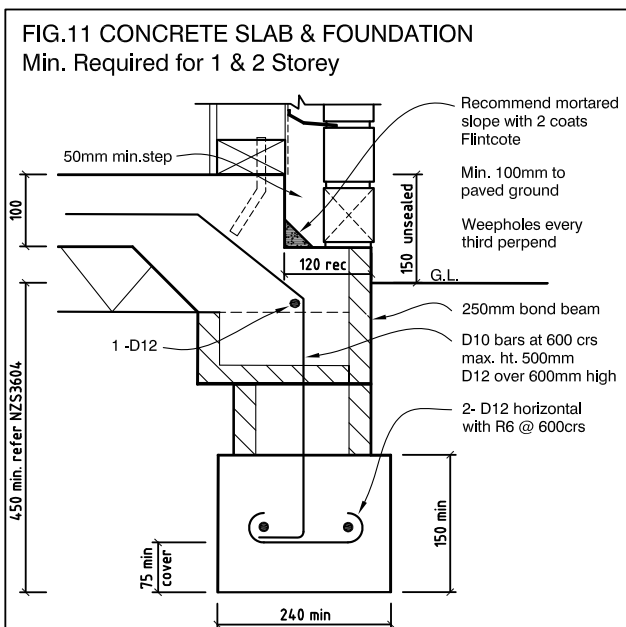
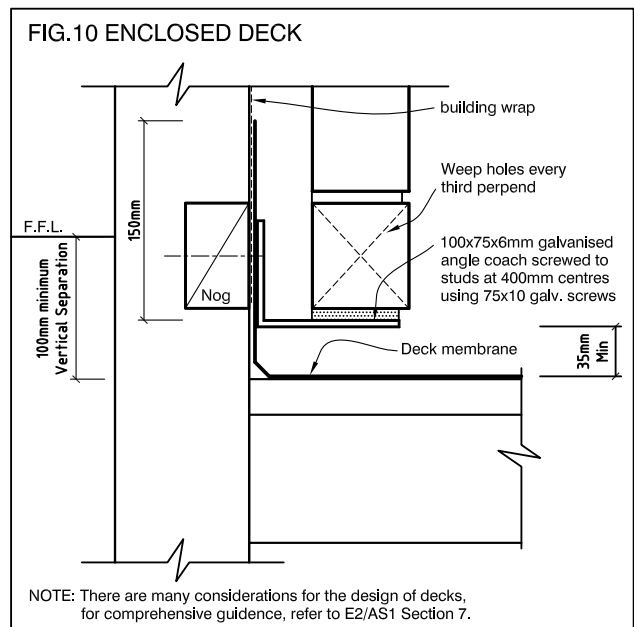
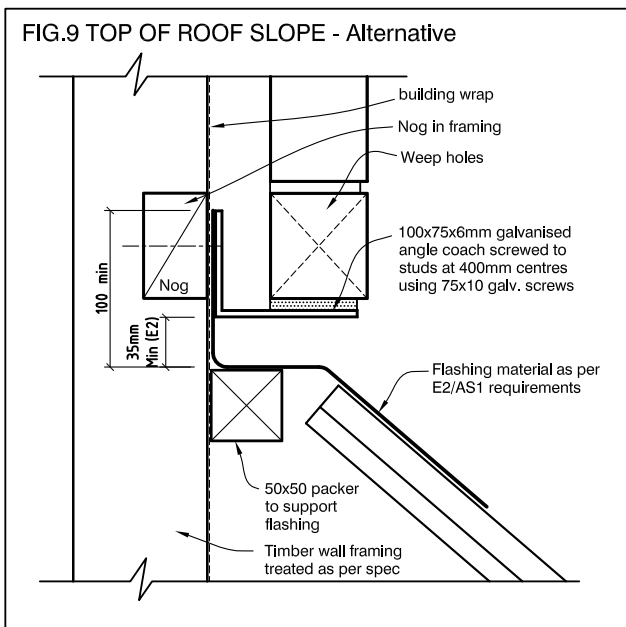
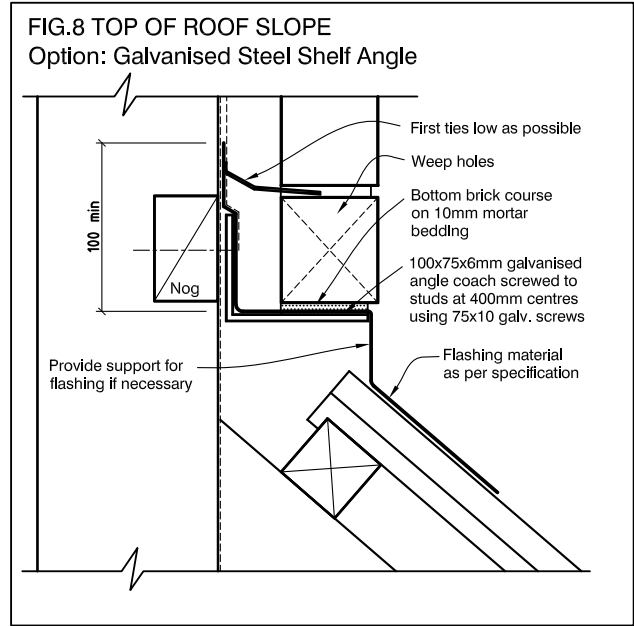
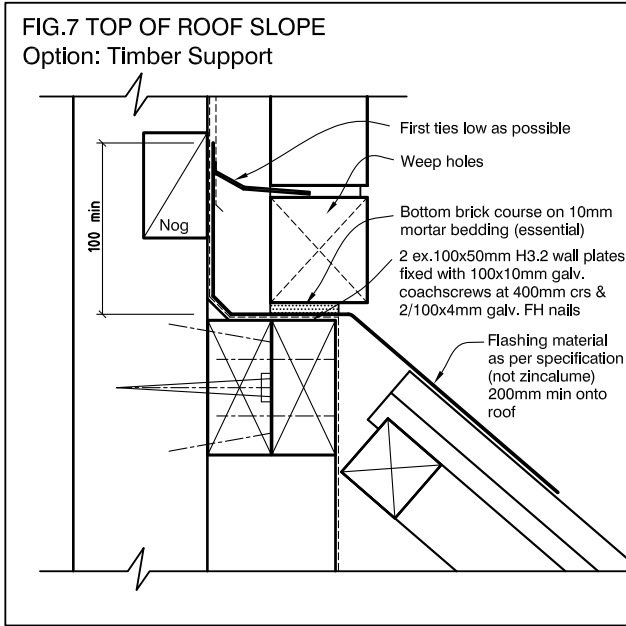


FIG.13 WINDOW HEAD - Aluminium

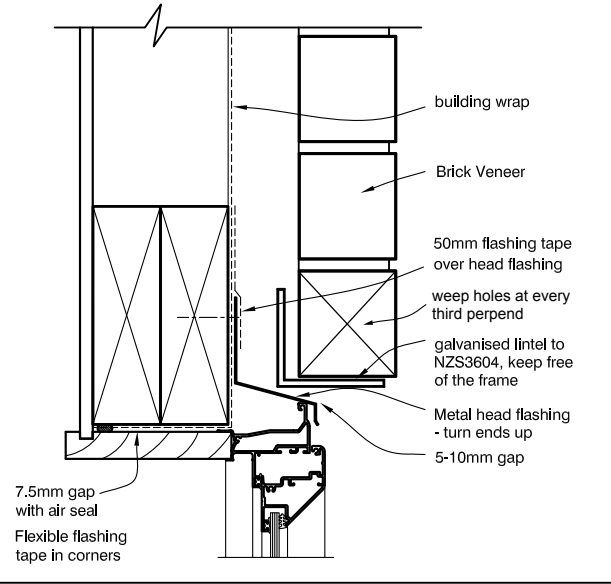


FIG.14 WINDOW JAMB - Aluminium

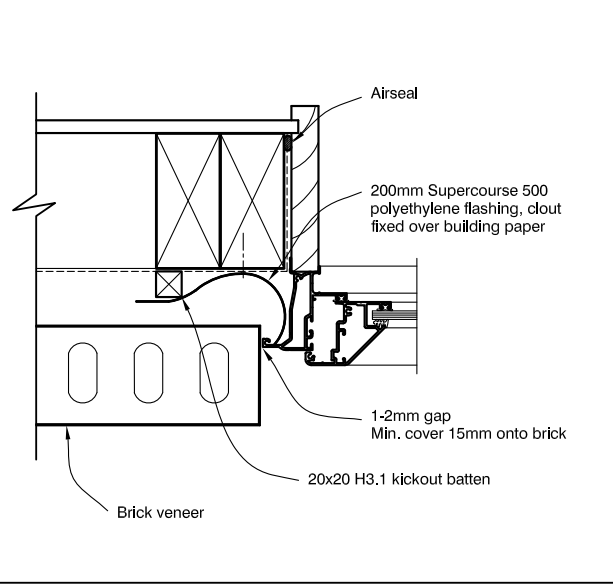


FIG.15 WINDOW SILL - Aluminium

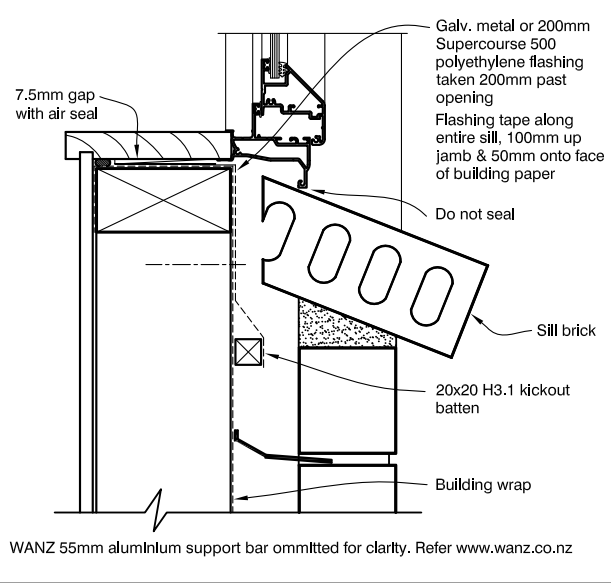


FIG.16 TYPICAL PIPE PENETRATION

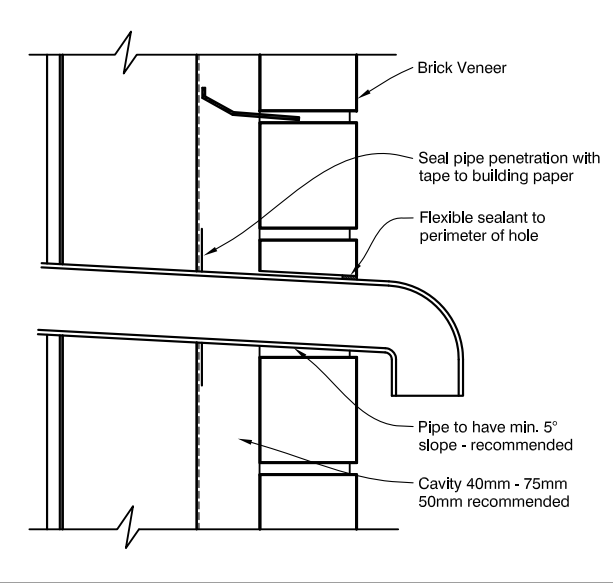


FIG.17 METER BOX

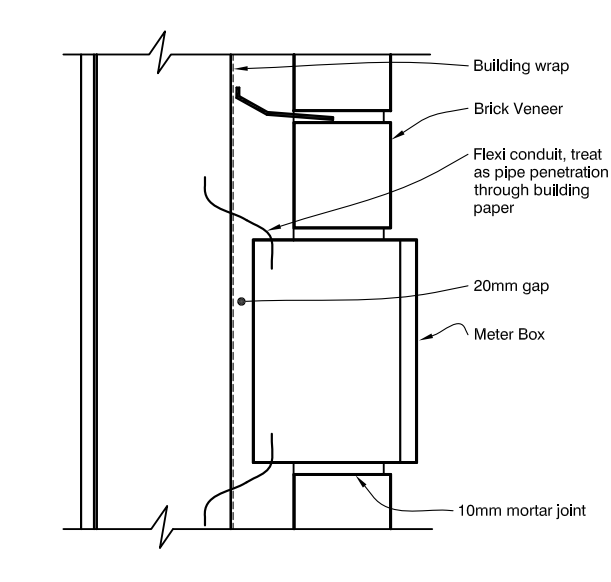
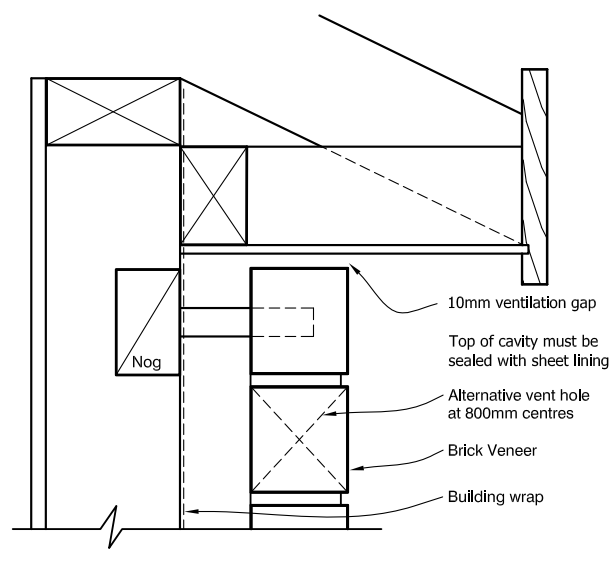
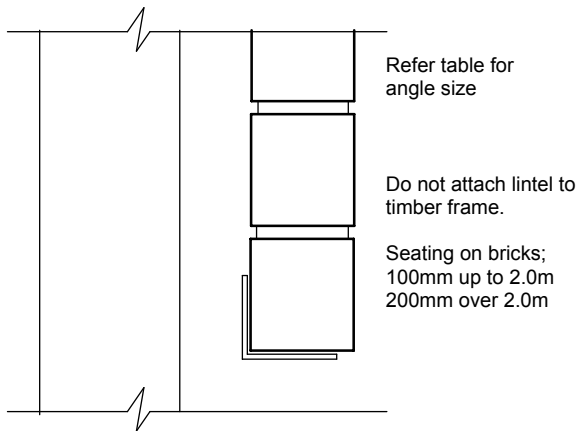


FIG.18 FLAT SOFFIT

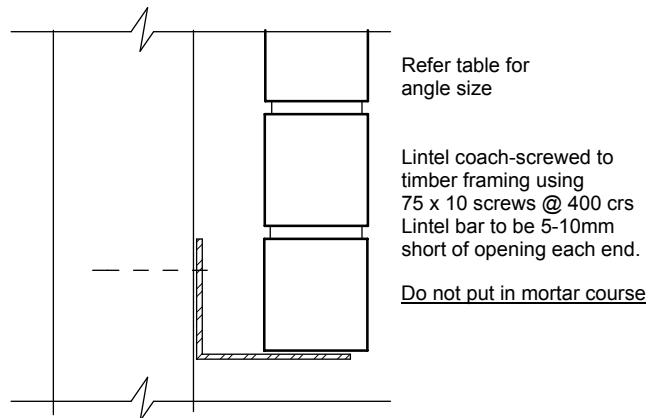


# LINTEL OPTIONS TO SUPPORT BRICKS OVER OPENINGS

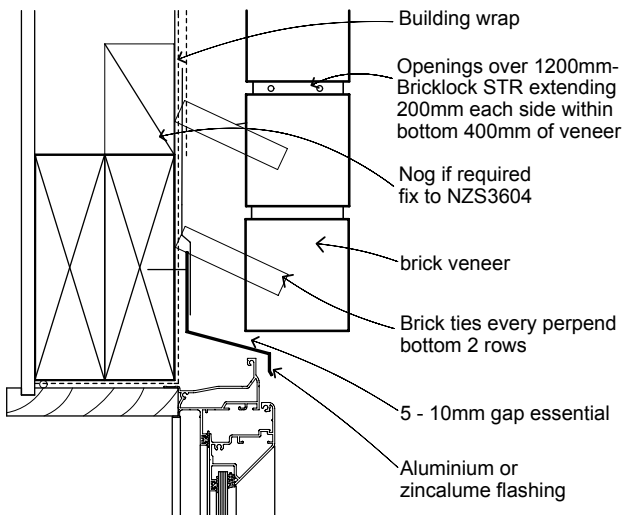
**Fig A. Lintel- Traditional**



**Fig B. Lintel- Fixed to framing**

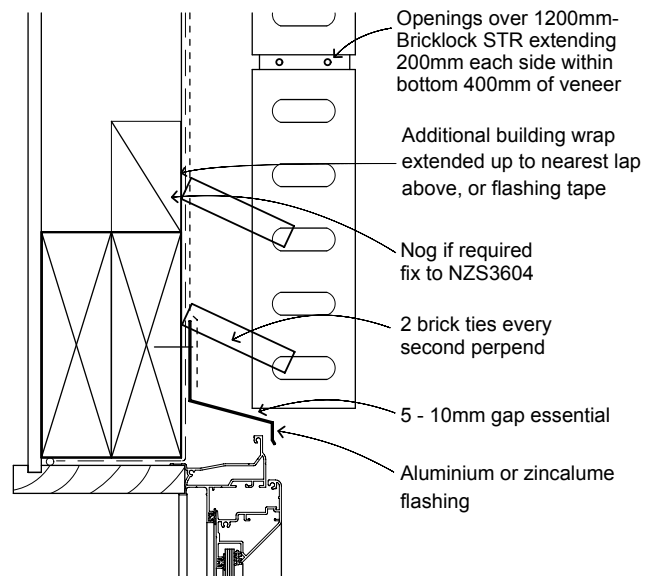


**Fig C. Steel-less Lintel- Standard Stretcher**

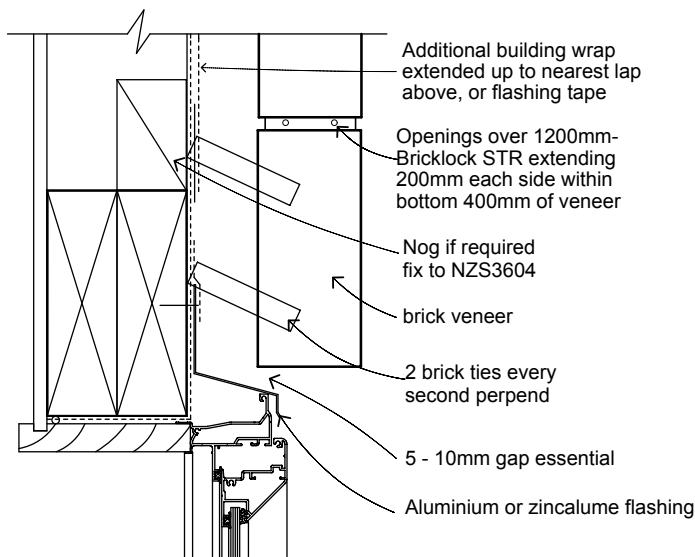


If the bricks are laid in this manner, the centre holes will be visible. A 'slip' may be glued underneath to hide the holes, but allow for this if not plastered

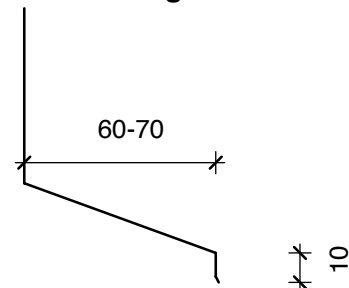
**Fig D. Steel-less Lintel- Soldier Course**



**Fig E. Double Height Brick**



**Fig F. Head Flashing**



**Notes:**

1. Flashing to be aluminum or zincalume.
2. Flashing may require packing out to suit.
3. Recommended on all windows.
4. Nail to timber framing with galv. flat head clouts, building wrap lapped over flashing, or fit flexible flashing tape.
5. The 10mm flashing leg to be positioned on external side of aluminum/window extrusion.

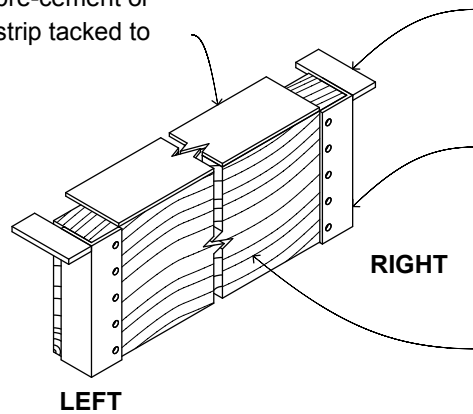
**Fig G. TEMPORARY SUPPORT OF BRICKS  
for steel-less lintels**

**LINTEL BRACKET**

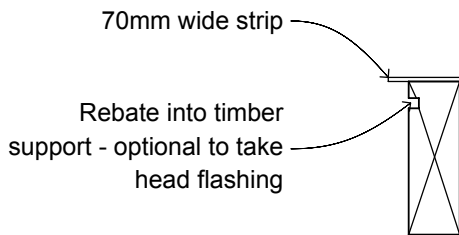
70mm wide fibre-cement or similar sheet strip tacked to timber

Reusable Bracket 70x30x6  
flat welding to angle

40x40 m.s. angle, 150mm  
long with 5 holes of 7mm  
dia secured using brick tie  
screws

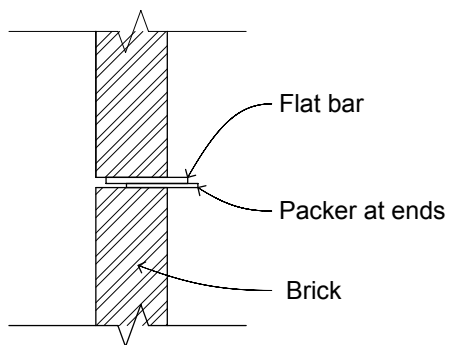


Timber Support:  
Openings up to 1.5m - 100x50  
Openings 1.5m to 2.4m - 150x50  
Openings over 2.4 - 2000x50

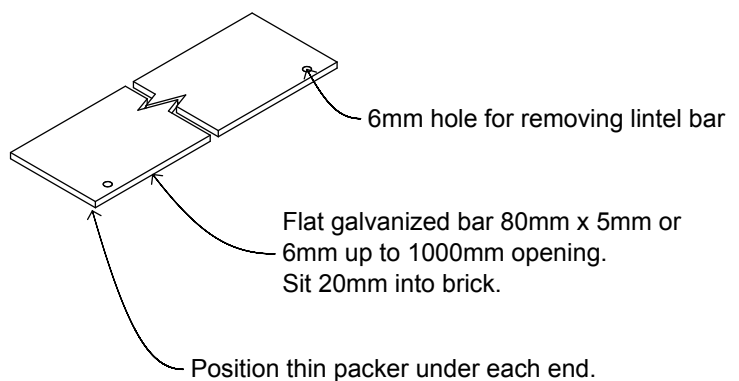


**Section Through  
Temporary Lintel Support**

**FLAT BAR- Openings < 1 metre**



**Section Detail**



**Isometric view**



# Appendix – Design Note TB1

## BRICKLAYING SPECIFICATION FOR TWO STOREY CLAY BRICK VENEERS

### 1.0 PRELIMINARY

Refer to the Preliminary and General Clauses of this specification and to the General Conditions of Contract, which are equally binding on all trades. All persons involved in the installation of this brick veneer must be aware of all aspects of this specification.

### 1.1 SCOPE

This section of the contract consists of the supply and laying of all brick veneer work veneer indicated on the drawings and specified herein and all associated lintels, ties etc. required for a complete contract.

### 1.2 WORKMANSHIP

Bricklaying shall be carried out by qualified tradesmen employed by a contractor specialising in the laying of brick. Bricklaying materials and workmanship shall conform in all respects to all the relevant requirements of NZ Standards and other relevant documents.

### 1.3 RELATED DOCUMENTS

In this section of the specification, reference is made to the latest revisions of the following documents:

AS/NZS 4455:1997	Masonry Units and Segmental Pavers
NZS 3602:2003	Timber and Wood Based Products for use in Building
NZS 3604:1999	Timber Framed Buildings (SANZ)
NZS 4210:2001	Masonry construction: materials and Workmanship (SANZ)
NZS 4230:2004	Design of Masonry Structures (SANZ)

AS/NZS 1170	Structural Design Actions
NZS 1170.5:2004	Structural Design Actions – Earthquake Action- New Zealand
NZS4229: 1999	Masonry Buildings not requiring Specific Design
NZS HB 4236	Masonry Veneer Wall Cladding – Summary of all Standards relating to brick veneer
NZBC B1/AS1	Structure – General, 2.0 Masonry
AS/NZS 2699.1	Built-in components for masonry construction-Wall ties
AS/NZS 2699.3	Built-in components for masonry construction – Lintels and Shelf Angles
NZS 3103	Sands for mortars and plasters
BRANZ Bulletin 436	Masonry Veneer construction

### 1.4 MANUFACTURER'S DOCUMENTS

In addition to this document, Design Note TB1, any manufacturer's and supplier's documents or brochures relating to brick and bricklaying shall apply.

## 2.0 PRODUCTS

### 2.1 General

All materials shall be the best of their respective kinds free from impurities, imperfections and other faults likely to impair the finished walls.

### Materials

#### 2.2 Bricks

Bricks shall be first quality clay bricks manufactured to comply with AS/NZS 4455. The bricks are to be the size and brand specified by the owner/architect/builder and must be either manufactured or marketed by a member of the NZCBG-PMA or have

their approval to use their system.

### 2.3 Mortar

Shall be manufactured from cement, sand, lime and additives complying with the relevant standards in NZS 4210:2001. Good mortar strength is essential.

All mortar used to lay bricks on this contract is to be a pre-bagged factory manufactured 'Trade Mortar' or site mixed at a ratio of 4 sand to 1 cement. Water and plasticizing agents are to be added to conform to the mortar manufacturer's specification.

### 2.4 Lintels and Shelf Angles

All steel lintels and shelf angles are to be galvanised and to comply with AS/NZS 2699.3. In Sea Spray Zones epoxy coated, or stainless steel.

Lintels are to be sized to comply with the table in Design Note TB1 or as specified by the structural engineer.

Where lintels span from one side of the veneer to the other in the traditional manner, the seating each side is to comply with NZS 3604 . Cl 11.7.6.2 **and not be attached in any way to the framing.**

Where the lintels are specified as being attached to the framing by way of galvanised bolts or coach screws, the steel lintel must be kept completely free of the brickwork and 5 mm short for face brick, 10 mm for plastered veneers, of the opening width each side of the opening.

### 2.5 Damp-proof course - opening flashings

Thermakraft 'Supercourse 500' polyethylene, 200 mm wide flashing, used to flash around all openings. The flashings are to be held off the building wrap using a 20 mm kick-out batten, or galvanised clouts left proud, allowing moisture to drop into the cavity. Flashings to extend 200 mm past openings in all directions.

## COMPONENTS

### 2.6 Metal Brick Ties

Brick ties, manufactured to AS/NZS2699.1, are to be used on this veneer. The ties must be of sufficient

length to ensure a minimum of 50% bedding in the mortar course. Refer to tables in Design Note TB1 for tie length. Ties are to be Stainless Steel in Sea Spray Zones epoxy coated, or stainless steel.

### 2.7 Reinforcement

Eagle Wire Products Ltd 'Bricklock STR 2.0 m and Bricklock CNR's.' or similar galvanised reinforcing wire.

## ACCESSORIES

### 2.8 Colouring Pigments

Use oxides to colour mortar where specified. This is to be added by volume and the architect or his agent advised of the quantity to be used to ensure consistency in the mortar colour.

### 2.9 Bitumen Damp-proof Membrane

The edge of slab and cavity are to be coated with 2 coats of bitumen emulsion, to architect's approval. Glued membrane d.p.c permitted.

## 3.0 BRICKLAYING

### IMPORTANT:

The bricklayer will be required to lay up a sample panel of the bricks, approx. 1.0 m square to demonstrate spread of colour (if laid as a face brick) and the mortar joints expected on the contract. If a 'bagged' finish is required, the sample panel will be used to demonstrate the finish to the architect's approval.

### 3.1 Tolerances

The brick veneer is not to exceed the maximum tolerances given in Table 2.2 NZS 4210.

### 3.2 Wet Weather

**Keep all bricks on site dry so** they do not become saturated. Keep the tops of pallets covered, bricks stacked around the site covered and the top of uncompleted veneers covered. This requirement applies during any inclement weather or when the job has been left for the day. All brick veneer **must be fully protected from rain for a period of 6**

**hours** after the bricks have been laid. Divert all down-pipes away from discharging water onto the veneer.

### 3.3 Protection of the Brick Veneer

The brick veneer is to be protected from damage and staining due to mortar, dirty water, paints and other chemicals at all times. Where necessary, the entire veneer is to be covered in polythene in order to protect it from contamination from building activities above and surrounding the veneer. Care is to be taken with the handling of scaffold and scaffold planks so as not to impact on the brick veneer. **NOTE: The builder must straighten the frame prior** to the bricks being laid to avoid excessive impact on the veneer.

### 3.4 Blending of the Bricks

#### **IMPORTANT**

(Applies if the veneer is to be laid as a face veneer)

The final appearance of the brickwork on this project is of the **utmost importance** and therefore will be inspected on a regular, sometimes on a daily basis, by the architect or his agent to ensure an acceptable standard of laying is achieved and maintained. Unacceptable bricklaying in the opinion of the architect or his agent will be removed and replaced at the expense of the bricklaying contractor.

All pallets shall be checked by the bricklayer on site for colour, batch number and quality, prior to commencing any laying. Any problems with the product must be sorted out with the supplier **before the bricks are laid.**

The bricks must be laid from at least three pallets where practical, to provide an **even spread of colour** over the total area of the wall. **Do not lay any bricks, which have obvious defects.** In the event this occurs or blending is NOT satisfactory, based on the opinion of the architect or his agent, the bricks concerned will be removed and replaced at the bricklayers cost.

### Bagged Brickwork

Where the brickwork is to be bagged and painted, the quality of the brick laying must be to face brick finish as contained within this specification. The

only variation to this requirement is the blending of the bricks, which is of no importance.

The degree of smearing of mortar over the face of the bricks is to be agreed upon between the architect, owner and the bricklayer, prior to the work commencing and should be considered a trial and error process in the initial stages of the contract to establish the finished appearance the architect requires.

### 3.5 Bonding of the Brickwork

Bricks shall be laid dry, in stretcher bond, with a half-bond pattern unless otherwise specified by the architect. Bricks shall not be stack-bonded apart from minor detailing. The minimum length of a piece of brick to be laid shall be no less than 60 mm.

### Soldier Courses

Bricks are to be laid as 'Soldier Courses' as and where specified on the Working Drawings or as directed by the architect. The bricks are to be laid perpendicular, evenly spaced and to be of an even thickness. Soldier bricks are to be tied every 2nd perpendicular joint to the structure. For double height bricks this shall be every perpendicular.

### 3.6 Mortar, Mortar joints and Pointing

All bricks shall be fully bedded in mortar.

All joints shall be 10 mm, +/- 2 mm, both horizontally and vertically (perpendiculars) and shall be **consistent in thickness**. No joint may be less than 7 mm or more than 13 mm; joints of these thicknesses should be the exception and certainly less than 5% of the total number of joints.

Mortar must be mixed **by volume** unless bagged. All joints may be raked to a depth of 5 mm and must not exceed 6 mm - tooled smooth. The tooling of the joint is to be done when the mortar is capable of retaining a finger print - this is to ensure consistency in the colour of the mortar.

However, where a 'Bagged' finish is specified the joint shall be finished flush to the architect's satisfaction.

**IMPORTANT:** If the air temperature exceeds 27° C or if there are warm winds blowing, common

in coastal areas, the bricks are to be lightly wetted and mortar cured over 48 hours to ensure 'Hydration' has occurred.

### 3.7 Brick Cavity

Form wall cavity between structural wall and brick veneer (minimum 40 mm – maximum 60 mm) and maintain cavity dimension indicated on the drawings; recommend 50 mm. Ensure the cavity is maintained clean of mortar droppings and clean mortar off ties as the work proceeds. Clean off mortar daggs and protrusions from the cavity face in order that the mortar does not encroach more than 5 mm into the cavity. It is essential that care be taken at this stage to avoid any bridging of the cavity. Ensure the brick cavity is sealed off from any roof space.

Take particular care to maintain a clean cavity. Clean out openings (wash-outs) shall be provided along the base, every 10th brick and at corners. This will apply on all levels and above Shelf Angles. Ensure that brickwork at lower levels is protected and thoroughly cleaned of mortar washings from upper levels on a daily basis.

### 3.8 Weep and Vent Holes

Form weep holes in the bottom course of walls at ground level, and wherever the cavity is closed at the base. Weep holes shall be formed every third perpend (or 1000 sqmm/lineal metre of wall) and shall be clean and free of mortar and other restrictions.

The above requirement shall apply equally for vent holes at the top of each section of veneer. **The vent holes are not to be placed in the perpend of the top row of bricks** but at least the next row down (or as specified) to protect the bonding strength of the bricks on the top row. In the event that an adequate gap is left at the top of the veneer, the vent holes may be omitted. Refer Fig. 18. If the veneer is waterproof, this requirement can be reduced by 50%, ie. 500 sqmm's per lineal metre of wall.

### 3.9 Brick ties

Brick ties are to be installed at a slope of 5 degrees at 400 mm centres horizontally into studs and at a maximum of 400 mm vertically.

Tie sizes shall vary to suit the varying widths of cavities. Wall tie anchorage shall be a minimum of half the width of the mortar bed, with 15 mm minimum cover from the weather face. Additional ties shall be placed within 200 mm of the edge around openings.

### 3.10 Joint reinforcement

It is recommended that galvanised wire joint reinforcement such as 'Bricklock STR' and 'Bricklock CNR' to be installed in the middle of the mortar bed thickness within the top 2.0 m of the veneer spaced approximately 800 mm apart and not in the same course as the ties. In plastered veneers, every 800 mm through the height of the veneer.

### 3.11 Window and Door Sills

All window and door sills will be laid in order that they are consistent in slope and overhang, or alternatively, as detailed on the working drawings.

Sill bricks or tiles will be laid in such a manner that **they are of a similar size in individual width** along the entire width of the window or door sill opening.

### 3.12 Cleaning of Brickwork

Clean all face work **as the work proceeds** using clean water and sponges. On completion, the brickwork is to be left in a clean condition, free of mortar smears and staining. Acid is not to be used to clean the bricks unless the brick manufacturer, the architect or his agent gives approval to do so. The veneer is **not to be water-blasted**.

Where the veneer is to be 'bagged and painted' the cleaning of the veneer is not as critical and can be left in a condition that is acceptable to the architect or his agent. This matter can be resolved at the time of the demonstration panel or at the commencement of the contract.

Vanadium salt stains (bright green/yellow) if present, are to be removed by the bricklayer on completion of the project by washing the bricks with a solution of Sodium Hydroxide (Caustic Soda) 60gm/litre of water.

Efflorescence – any white salts are to be removed from the brickwork. Brush with a stiff-bristle broom

and take away brushings from the locality. Remove remaining deposit with a damp sponge. Repeat this process as necessary through to the completion of the contract. Note: keeping bricks and brickwork dry during the construction phase will eliminate most issues to do with efflorescence.

Where scaffold planks are at an upper level, brickwork is to be protected from mortar stains and **cleaned** on a daily basis to reduce the potential of mortar stains down the veneer.

### IMPORTANT NOTE:

Should there be any conflict between the information in this 'General 2 Storey Specification' and the information in Design Note TB1, the latter shall always take precedence.

### 3.13 Lintels and Shelf Angles

It is the responsibility of the bricklayer to ensure all lintels are installed correctly as per plans, details and specified in Design Note TB1. Ensure durability requirements are satisfied for the location of the dwelling.

### 4.0 FLASHINGS

- 4.1 Head flashings are to be installed as per drawings.
- 4.2 Supercourse 500 being 200 mm in width is to be used to flash around all windows and openings. A 20 mm kick-out batten is to be installed.
- 4.3 It is the responsibility of the bricklayer to ensure all flashings are installed as per drawings prior to bricks being laid in the area concerned.

### 5.0 CONTROL JOINTS

Control joints, 10 mm wide, are to be installed as per plans unless otherwise directed by the architect or his agent, during the progress of the contract. The joints are to be filled with a flexible sealant of a similar colour to the mortar.

### 6.0 INSPECTIONS

All inspections will be carried out by the appropriate authorities. It is the bricklayer's responsibility to call for all necessary inspections involving his trade. For whatever reason, if a mandatory inspection, for example, half-height, is not done, it is the **responsibility** of the bricklayer to ensure that the architect or his agent, is advised **prior** to continuing work in the area concerned.





# THE BRICKERY®



Canterbury **Clay**Bricks

**Midland Brick NZ**  
CLAY BRICKS & PAVERS



**CLAY BRICK & PAVER**  
MANUFACTURER'S ASSOCIATION

[www.bricksnz.co.nz](http://www.bricksnz.co.nz)